

ICOM

INSTRUCTION MANUAL

VHF TRANSCEIVER

IC-H19s1

Icom Inc.



IMPORTANT

READ THESE INSTRUCTIONS carefully and completely before using the transceiver.

SAVE THIS INSTRUCTION MANUAL. This instruction manual contains important safety and operating instructions for the transceiver.

CAUTIONS

WARNING: The transceiver **DOES NOT** meet required intrinsically-safe ratings when an unauthorized option is used. Refer to p. 6 for details.

NEVER expose the transceiver to heavy rain, snow, or liquids of any kind.

NEVER disassemble the transceiver. Incorrect reassembly may result in a fire or explosion hazard.

NEVER allow children to touch the transceiver.

FOREWORD

Thank you for purchasing the IC-H19S1 VHF TRANSCEIVER.

The transceiver is an intrinsically-safe type when used with the supplied CM-71 BATTERY PACK and also meets strict MIL (U.S.A. military) standards 810C and 810D.

UNPACKING

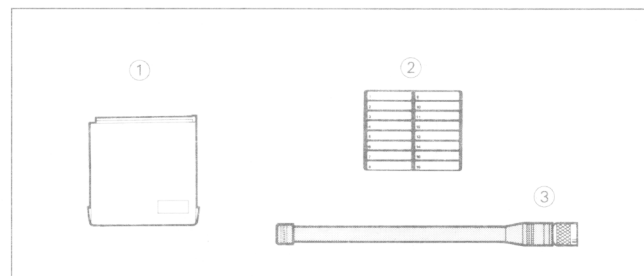

Accessories included with the IC-H19S1:	Qty.
① Battery pack (CM-71)	1
② Channel memo sticker	1
③ Flexible antenna (FA-155T)	1

CONTROL FUNCTIONS

1

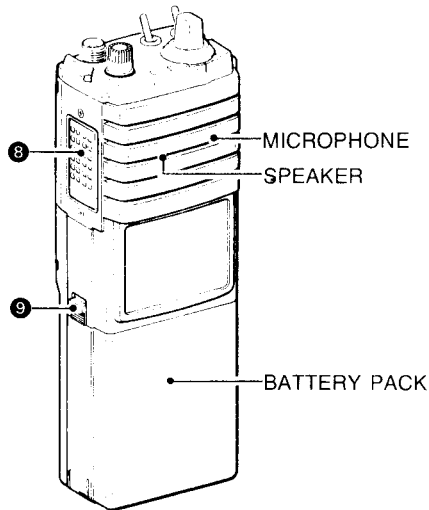
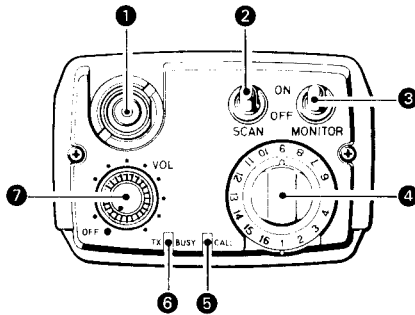

1 ANTENNA CONNECTOR

Connects the supplied flexible antenna.

2 SCAN SWITCH [SCAN]

Turns scan function ON and OFF.

3 MONITOR SWITCH [MONITOR]

Allows you to monitor a signal on the selected channel.

4 CHANNEL SELECTOR

Selects an operating channel.

5 CALL INDICATOR [CALL]

Lights up in red when a selected call is received.

6 TRANSMIT/BUSY INDICATOR [TX/BUSY]

- Lights up in red while transmitting.

- Lights up in green when the selected channel is busy.

7 POWER SWITCH/VOLUME CONTROL [VOL]

Turns the power ON and OFF, and adjusts the audio output level.

8 PTT SWITCH

Push and hold to transmit and release to receive.

9 BATTERY PACK RELEASE BUTTON

Allows the battery pack to be removed from the transceiver.

■ Antenna connection

Connect the supplied flexible antenna into the antenna connector on the top panel of the transceiver. Screw down securely.

■ Battery pack replacement

The power **MUST** be turned OFF before replacing the battery pack. Rotate [VOL] counterclockwise until you hear a click to turn OFF the power.

Push upward and hold the battery pack release button, then slide the battery pack to the right with the transceiver facing you.

• Battery pack removal

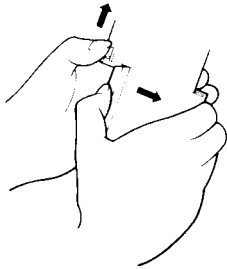

■ Battery pack charging

Prior to using the transceiver for the first time, the battery pack **MUST** be fully charged using an optional BM-75 MULTI-CHARGER or BM-70/E AC BATTERY CHARGER.

NOTE: The transceiver power **MUST** be OFF if a battery pack is to be charged while it is attached to the transceiver.

- 1) Connect the battery charger to a domestic AC outlet with the supplied AC power cable.
- 2) Insert the battery pack into the charging slot with the front of the battery pack facing you.
 - The charging indicator lights up in red.
- 3) Pull out the charged battery pack when
 - BM-75 : The yellow indicator lights.
 - BM-70/E : The charging indicator goes out.
 - Charging time
 - BM-70/E : Approx. 60 min.
 - BM-75 : Approx. 90 min. (up to 3 battery packs)
Approx. 180 min. (up to 6 battery packs)

Refer to the BM-75 or BM-70/E instruction manual for details.

■ Battery pack cautions

NEVER expose the battery pack to fire, as internally generated battery gas may cause an explosion.

NEVER put the battery pack in water. If the battery pack becomes wet, be sure to wipe it dry.

NEVER short circuit the terminals of the battery pack as internal components may be damaged and current may flow into nearby metal objects.

AVOID charging the battery pack in extreme cold (under 0°C) or extreme heat (over +40°C). The battery pack may not be charged fully at these extremes of temperature.

When the operating time between successive charges becomes much shorter than that for a new battery pack, the battery pack may be reaching the end of its operating life. At this time, a new battery pack should be purchased.

■ Low battery condition

When [TX/BUSY] goes out or fails to light up during transmission, the battery pack should be recharged or replaced with a fully charged battery pack.

■ Intrinsically safe type

The transceiver is intrinsically safe when operating under the conditions described below.

In Class I, division 1, groups C and D atmospheric conditions; plus, Class II division 1, groups E, F and G atmospheric conditions when in groups E and F dust resistance is greater than $10^5 \Omega/\text{cm}$. Max. temperature range is T4A.

■ Nonincentive type

The transceiver is nonincentive when operating under the conditions described below.

In Class I, division 2, groups A, B, C and D atmospheric conditions. Max. temperature range is T4A.

3

OPERATION

NOTE: When an optional UT-59 DTCS UNIT is installed, operation differs from the following procedure. Ask your Icom Dealer for details.

■ Receiving

- 1** Set switches as follows:
 - [MONITOR] : OFF position
 - [SCAN] : OFF position
- 2** Set [VOL] to the 10 o'clock position.
 - Power comes ON.
- 3** Set the channel selector to the desired channel position.
- 4** When receiving a call, adjust [VOL] to the desired audio output level, if needed.
 - [TX/BUSY] lights up in green and [CALL] lights up in red.
- 5** When [TX/BUSY] lights up in green and no audio is heard, turn ON [MONITOR] to monitor the channel, if needed.
- 6** To search a programmed channel automatically, turn ON [SCAN].

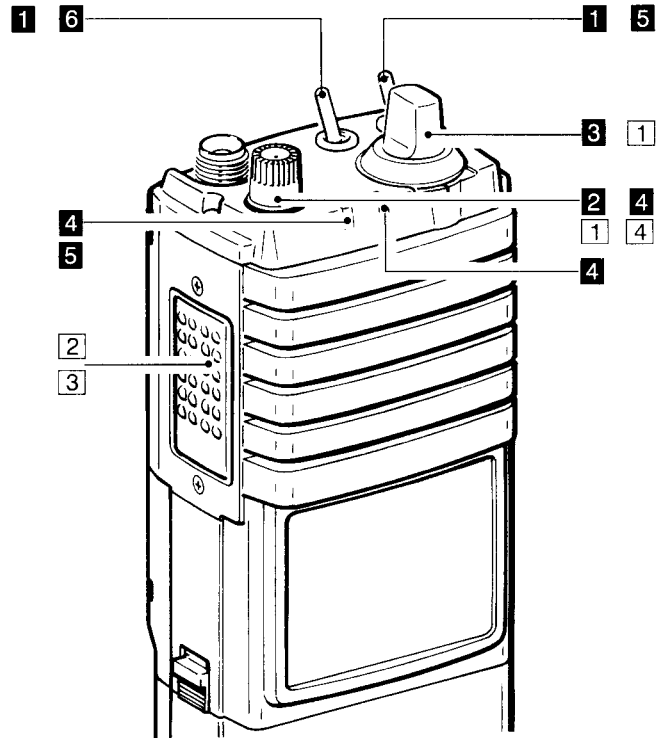

■ Transmitting

CAUTION: Transmitting without an antenna may damage the transceiver.

NOTE: DO NOT transmit when [TX/BUSY] lights up in green. Your transmission may interfere with another station.

- 1 Turn ON power and set the channel selector to the desired channel position.
- 2 Push and hold the PTT switch, and speak into the microphone.
 - [TX/BUSY] lights up in red.
 - DO NOT hold the transceiver too close to your mouth or speak too loudly. This may distort the signal.
- 3 Release the PTT switch to return to receive.
- 4 To turn OFF the power, rotate [VOL] counterclockwise until you hear a click.

WARNING: When the optional CM-72, CM-73 BATTERY PACKS or UT-42 DTMF ENCODER UNIT is used, the transceiver is **NOT** an intrinsically-safe type.

- **BM-70/E AC BATTERY CHARGER** Desktop type. Rapidly charges the CM-71 within approx. 60 min.
- **BM-75 MULTI-CHARGER** Charges up to 6 separate CM-71 ~ CM-73 within approx. 180 min. Only approx. 90 min. charging time for 1 ~ 3 separate CM-71 ~ CM-73.
- **CM-71 BATTERY PACK** An intrinsically-safe type. 7.2 V, 1000 mAh.
- **CM-72 BATTERY PACK** 8.4 V, 1000 mAh.
- **CM-73 BATTERY PACK** 13.2 V, 1000 mAh.
- **HG-1 CHARGER HANGER** Mounts the BM-75 on a wall.
- **UT-42 DTMF ENCODER UNIT** Provides repeater control and autopatch operation.
- **UT-59 DTCS UNIT** Ensures advanced, quiet standby and selective calling with a 3-digit code. A total of 177 codes are available.

Count on us!

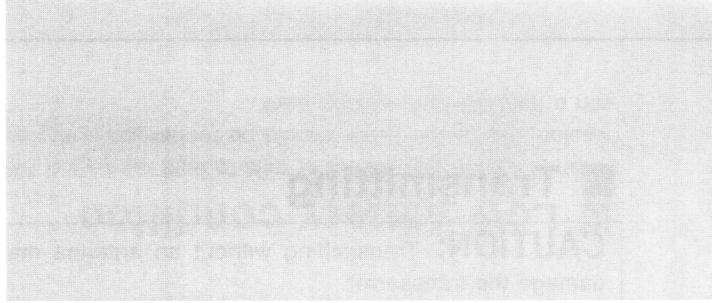

A-5120S-1EX
Printed in Japan
Copyright © 1990 by Icom Inc.

Icom Inc.
6-9-16, Kamihigashi, Hirano-ku, Osaka 547, Japan
